

Limit switches

OsiSense XC Standard, format EN 50041
Plastic, double insulated, XCKS

1

Complete switch

with 2 contacts (NO + NC) and 1 cable entry

■ The OsiSense XCKS limit switches range, with 2 integrated contacts, offers "all-in-one", ready to use products.

□ XCKS, with head for linear (plunger) and rotary (lever) movement



Variable composition switch

with 2, 3 or 4 contacts and 1 cable entry

■ The variable composition range expands the offer up to 4 contacts and choice among 18 different actuators.

□ ZCKD: complete head with linear or rotary actuator
□ ZCKS: bodies with 2, 3 or 4 contacts



Environment characteristics

Conformity to standards	Products	EN/IEC 60947-5-1, UL 508, CSA C22-2 n°14, CCC, EAC
	Machine assemblies	EN/IEC 60204-1
Product certifications		UL, CSA, CCC, EAC
Protective treatment	Version	Standard "TC", special "TH"
Ambient air temperature	For operation	- 25...+ 70 °C
	For storage	- 40...+ 70 °C
Vibration resistance	Conforming to EN/IEC 60068-2-6	25 gn (10...500 Hz)
Shock resistance	Conforming to EN/IEC 60068-2-27	XCKS1●●: 40 gn (11 ms) XCKS5●●: 50 gn (11 ms)
Electric shock protection	Conforming to EN/IEC 61140	Class II
Degree of protection	Conforming to EN/IEC 60529	XCKS1●●, XCKS5●●: IP 66 and IP 67 ZCKS: IP 65
	Conforming to EN 62262	XCKS1●●, XCKS5●●: IK 05 ZCKS: IK 03
Cable entry	Depending on model	Tapped entry for n° 13 cable gland or tapped ISO M20 x 1.5
Materials		Bodies and heads: plastic



Contact block characteristics

Type of contacts	Conforming to EN/IEC 60947-5-1	Type Zb, electrically separate double break contacts
Positive operation (depending on model)		NC contacts with positive opening operation conforming to EN/IEC 60947-5-1 Appendix K
Rated operational characteristics	XCKS1●●, XCKS5●● XE2●P●, XESP●	~ AC-15 ; A300 (Ue = 240 V, Ie = 3 A) ; Ithe = 10 A --- DC-13 ; Q300 (Ue = 250 V, Ie = 0.27 A), conforming to EN/IEC 60947-5-1 Appendix A
	XE3●P●	~ AC-15 ; B300 (Ue = 240 V, Ie = 1.5 A) ; Ithe = 6 A --- DC-13 ; R300 (Ue = 250 V, Ie = 0.1 A), conforming to EN/IEC 60947-5-1 Appendix A
Rated insulation voltage	XCKS1●●, XCKS5●● XE2●P●, XESP●	Ui = 500 V degree of pollution 3 conforming to EN/IEC 60947-5-1
	XE3●P●	Ui = 300 V conforming to UL 508 and CSA C22-2 n° 14
Rated impulse withstand voltage	XCKS1●●, XCKS5●● XE2●P●, XESP●	U imp = 6 kV conforming to EN/IEC 60947-1, IEC 60664
	XE3●P●	U imp = 4 kV conforming to EN/IEC 60947-1, IEC 60664
Short-circuit protection	XCKS1●●, XCKS5●● XE2●P●, XESP●	10 A cartridge fuse type gG (gl)
	XE3●P●	6 A cartridge fuse type gG (gl)
Resistance across terminals		≤ 25 mΩ conforming to EN/IEC 60255-7 category 3
Connection (screw clamp terminals)	XCKS1●●, XCKS5●● XE2SP21●1	Clamping capacity, min: 1 x 0.34 mm ² / AWG 22, max: 2 x 1.5 mm ² / AWG 16
	XE2NP21●1	Clamping capacity, min: 1 x 0.5 mm ² / AWG 20, max: 2 x 2.5 mm ² / AWG 14
	XESP●	Clamping capacity, min: 1 x 0.75 mm ² / AWG 20, max: 2 x 1.5 mm ² / AWG 16
	XE3●P●	Clamping capacity, min: 1 x 0.34 mm ² / AWG 22, max: 1 x 1 mm ² / AWG 18 or 2 x 0.75 mm ² / AWG 20
Minimum actuation speed		Snap action contacts (XCKS1●, XE●SP● and XESP●): 0.01 m/minute Slow break contacts (XCKS5●, XE2NP● and XE3NP●): 6 m/minute
Electrical durability	XCKS1●● + LC1D38 / ~ 230 V	15 million operating cycles
	XCKS5●● + LC1D38 / ~ 230 V	20 million operating cycles
	ZCKS	<ul style="list-style-type: none"> ■ Conforming to IEC 60947-5-1 Appendix C ■ Utilisation categories AC-15 and DC-13 ■ Maximum operating rate: 3600 operating cycles/hour ■ Load factor: 0.5

	XE2SP21●1, XE2SP2141	XE2NP21●1	XESP3021																								
AC supply 50/60 Hz ~ mm inductive circuit																											
DC supply ---	Power broken in W for 5 million operating cycles. <table border="1"> <tr><th>Voltage V</th><th>24</th><th>48</th><th>120</th></tr> <tr><th>mm W</th><td>10</td><td>7</td><td>4</td></tr> </table>	Voltage V	24	48	120	mm W	10	7	4	Power broken in W for 5 million operating cycles. <table border="1"> <tr><th>Voltage V</th><th>24</th><th>48</th><th>120</th></tr> <tr><th>mm W</th><td>13</td><td>9</td><td>7</td></tr> </table>	Voltage V	24	48	120	mm W	13	9	7	Power broken in W for 5 million operating cycles. <table border="1"> <tr><th>Voltage V</th><th>24</th><th>48</th><th>120</th></tr> <tr><th>mm W</th><td>10</td><td>7</td><td>4</td></tr> </table>	Voltage V	24	48	120	mm W	10	7	4
Voltage V	24	48	120																								
mm W	10	7	4																								
Voltage V	24	48	120																								
mm W	13	9	7																								
Voltage V	24	48	120																								
mm W	10	7	4																								
<i>For XE2S P●151 on ~ or ---, NC and NO contacts simultaneously loaded to the values shown with reverse polarity.</i>																											

	XE3SP●●●●	XE3NP●●●●																
AC supply 50/60 Hz ~ mm inductive circuit																		
DC supply ---	Power broken in W for 5 million operating cycles. <table border="1"> <tr><th>Voltage V</th><th>24</th><th>48</th><th>120</th></tr> <tr><th>mm W</th><td>3</td><td>2</td><td>1</td></tr> </table>	Voltage V	24	48	120	mm W	3	2	1	Power broken in W for 5 million operating cycles. <table border="1"> <tr><th>Voltage V</th><th>24</th><th>48</th><th>120</th></tr> <tr><th>mm W</th><td>4</td><td>3</td><td>2</td></tr> </table>	Voltage V	24	48	120	mm W	4	3	2
Voltage V	24	48	120															
mm W	3	2	1															
Voltage V	24	48	120															
mm W	4	3	2															

Limit switches

OsiSense XC Standard, format EN 50041

Plastic, double insulated, XCKS

Complete switches with 1 cable entry

1

Type of head	Plunger (fixing by the body)	Rotary (fixing by the body)
--------------	------------------------------	-----------------------------



Form conforming to EN 50041 (1)	B	C	A	A	A	A	D
Type of operator	Metal end plunger	Steel roller plunger	Thermoplastic or steel roller lever (2)	Elastomer roller lever, Ø 50 mm (2)	Variable length thermoplastic or steel roller lever (2)	Variable length elastomer roller lever, Ø 50 mm (2)	Round thermoplastic rod lever, Ø 6 mm (3) (4)
Positive operation	⊖	⊖	⊖	—	⊖	—	—

References of complete switches with 1 ISO M20 x 1.5 cable entry

<p>2-pole NC + NO snap action</p>	XCKS101H29	XCKS102H29	XCKS131H29 (thermoplastic) XCKS133H29 (steel)	XCKS139H29	XCKS141H29 (thermoplastic) XCKS143H29 (steel)	XCKS149H29	XCKS159H29
<p>2-pole NC + NO break before make, slow break</p>	XCKS501H29	XCKS502H29	XCKS531H29 (thermoplastic) XCKS533H29 (steel)	XCKS539H29	XCKS541H29 (thermoplastic) XCKS543H29 (steel)	XCKS549H29	XCKS559H29
Weight (kg)	0.125	0.135	0.160	0.175	0.165	0.180	0.170
Contact operation			(A) = cam displacement (P) = positive opening point		⊖ NC contact with positive opening operation		

References of complete switches with 1 Pg 13.5 cable entry

For an entry tapped for a Pg 13.5 cable gland, delete H29 from the end of the reference. (Except XCKS133H29, XCKS143H29, XCKS533H29 and XCKS543H29). Example: XCKS101H29 becomes XCKS101.

Characteristics

Switch actuation	On end	By 30° cam		By any moving part		
Type of actuation						
Maximum actuation speed	0.5 m/s	1.5 m/s		1 m/s		
Mechanical durability (in millions of operating cycles)	25	15	20			
Minimum force or torque	For tripping	15 N	12 N	0.10 N.m		
	For positive opening	30 N	20 N	0.15 N.m	—	0.15 N.m
Cable entry	1 entry tapped M20 x 1.5 mm for ISO cable gland, clamping capacity 7 to 13 mm					

(1) Form conforming to EN 50041, see page 1/137.
 (2) Adjustable throughout 360° in 5° steps, or in 90° steps by reversing the notched washer.
 (3) Adjustable throughout 360° in 5° steps, or in 45° steps by reversing the lever mounting.
 (4) Value taken with actuation by moving part at 100 mm from the fixing.

Limit switches

OsiSense XC Standard, format EN 50041

Plastic, double insulated, XCKs

Variable composition switches with 1 cable entry



Note: ZCKD heads can only be used with ZCKS bodies.

References of variable composition switches (ZCKS bodies and ZCKD heads) with 1 ISO M20 x 1.5 cable entry (3)							
Form conforming to EN 50041 (1)	B	C	A	A	A	A	D
Type of operator	Metal end plunger	Steel roller plunger	Thermoplastic roller lever (2)	Elastomer roller lever, Ø 50 mm (2)	Variable length thermoplastic roller lever (2)	Variable length elastomer roller lever, Ø 50 mm (2)	Round thermoplastic rod lever, Ø 6 mm (4) (5)
Positive operation				—		—	—
2-pole NC + NC snap action (XE2SP2141)	ZCKS9H29 + ZCKD01 	ZCKS9H29 + ZCKD02 	ZCKS9H29 + ZCKD31 	ZCKS9H29 + ZCKD39 	ZCKS9H29 + ZCKD41 	ZCKS9H29 + ZCKD49 	ZCKS9H29 + ZCKD59
2-pole NC + NC simultaneous, slow break (XE2NP2141)	ZCKS7H29 + ZCKD01 	ZCKS7H29 + ZCKD02 	ZCKS7H29 + ZCKD31 	ZCKS7H29 + ZCKD39 	ZCKS7H29 + ZCKD41 	ZCKS7H29 + ZCKD49 	ZCKS7H29 + ZCKD59
3-pole NC + NC + NO snap action (XE3SP2141)	ZCKSD39H29 + ZCKD01 	ZCKSD39H29 + ZCKD02 	ZCKSD39H29 + ZCKD31 	ZCKSD39H29 + ZCKD39 	ZCKSD39H29 + ZCKD41 	ZCKSD39H29 + ZCKD49 	ZCKSD39H29 + ZCKD59
3-pole NC + NC + NO break before make, slow break (XE3NP2141)	ZCKSD37H29 + ZCKD01 	ZCKSD37H29 + ZCKD02 	ZCKSD37H29 + ZCKD31 	ZCKSD37H29 + ZCKD39 	ZCKSD37H29 + ZCKD41 	ZCKSD37H29 + ZCKD49 	ZCKSD37H29 + ZCKD59
Weight (kg)	0.095	0.105	0.145	0.150	0.155	0.155	0.150
Contact operation			(A) = cam displacement (P) = positive opening point				

References of variable composition switches (ZCKS bodies and ZCKD heads) with 1 Pg 13.5 cable entry

For ZCKS bodies with 1 Pg 13.5 cable entry, delete H29 from the end of the reference. Example: ZCKS1H29 becomes ZCKS1.

Characteristics							
Switch actuation	On end	By 30° cam			By any moving part		
Type of actuation				or			
Maximum actuation speed	0.5 m/s	1.5 m/s			1 m/s		
Mechanical durability (6) (in millions of operating cycles)	25	15	20				
Minimum force or torque	For tripping: 15 N For positive opening: 45 N	12 N 36 N	0.15 N.m 0.3 N.m			0.3 N.m	—
Cable entry	1 entry tapped M20 x 1.5 mm for ISO cable gland, clamping capacity 7 to 13 mm						

(1) Form conforming to EN 50041, see page 1/137.
 (2) Adjustable throughout 360° in 5° steps, or in 90° steps by reversing the notched washer.
 (3) Switches with gold contacts or eyelet type connections: please consult our Customer Care Centre.
 (4) Adjustable throughout 360° in 5° steps, or in 45° steps by reversing the lever mounting.
 (5) Value taken with actuation by moving part at 100 mm from the fixing.
 (6) Limited to 15 million operating cycles for switches with contacts XE3•P.

Limit switches

OsiSense XC Standard, format EN 50041

Plastic, double insulated, XCKS

Complete switches with 1 cable entry

Dimensions

XCKS●01●●

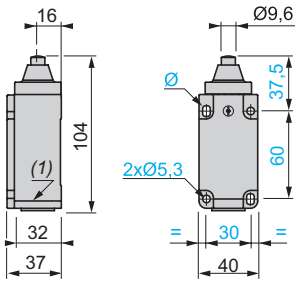

XCKS●02●●

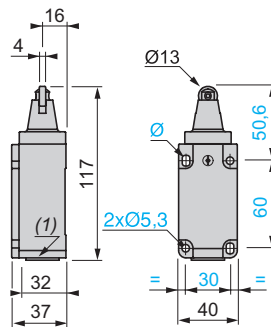

XCKS●31●● / XCKS●33●●

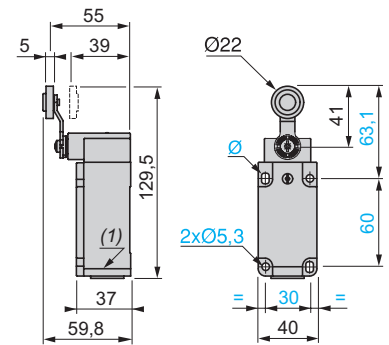

XCKS●39●●

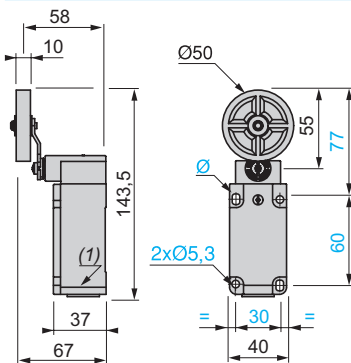

XCKS●41●● / XCKS●43●●

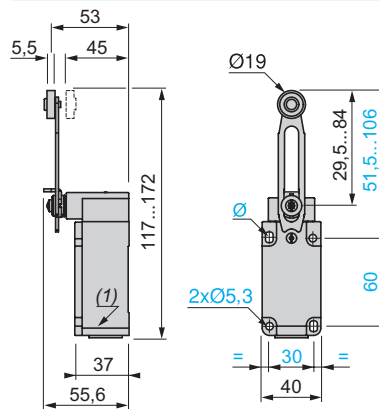

XCKS●49●●

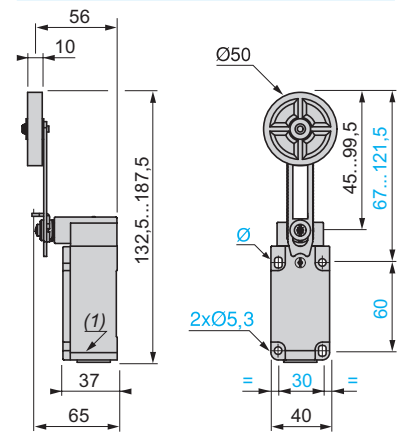

XCKS●59●●

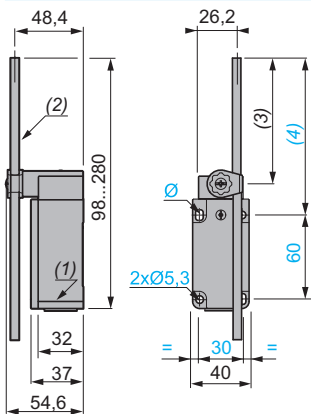

(1) 1 tapped entry for ISO M20 x 1.5 or Pg 13.5 cable gland.

(2) Ø 6 rode, lenght 200 mm.

(3) 190 max.

(4) 212 max.

Ø : 2 elongated holes 5.3 x 7.3 mm.

Limit switches

OsiSense XC Standard, format EN 50041

Plastic, double insulated, XCKS

Variable composition switches with 1 cable entry

Dimensions

ZCKS● + ZCKD01

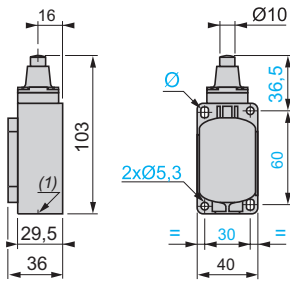

ZCKS● + ZCKD02

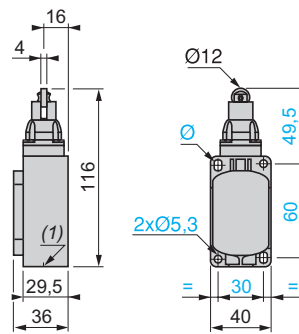

ZCKS● + ZCKD31

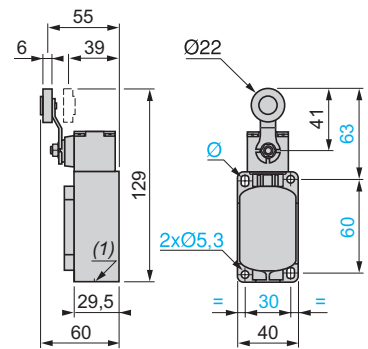

ZCKS● + ZCKD39

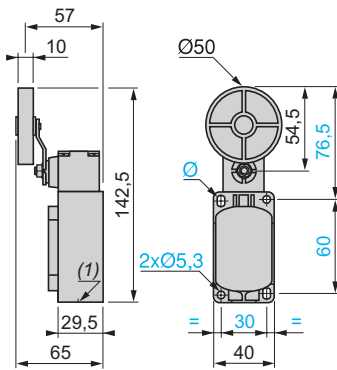

ZCKS● + ZCKD41

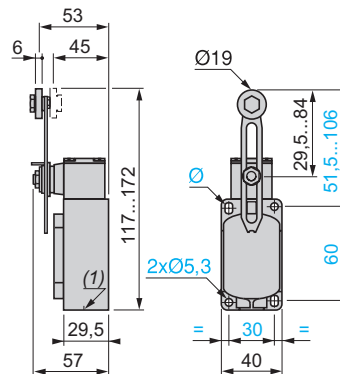

ZCKS● + ZCKD49

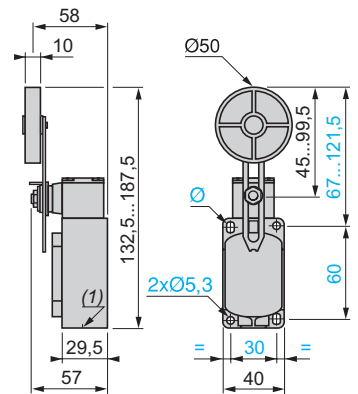

ZCKS● + ZCKD59

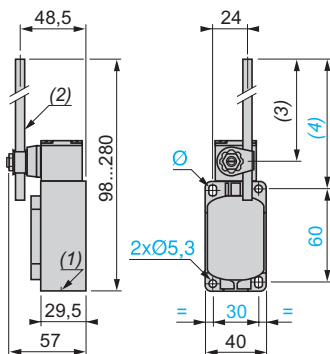

(1) 1 tapped entry for ISO M20 x 1.5 or Pg 13.5 cable gland.

(2) Ø 6 rode, lenght 200 mm.

(3) 190 max.

(4) 212 max.

Ø : 2 elongated holes 5.3 x 7.3 mm.

Limit switches

OsiSense XC Standard, format EN 50041

Plastic, double insulated, XCKS

Variable composition

1

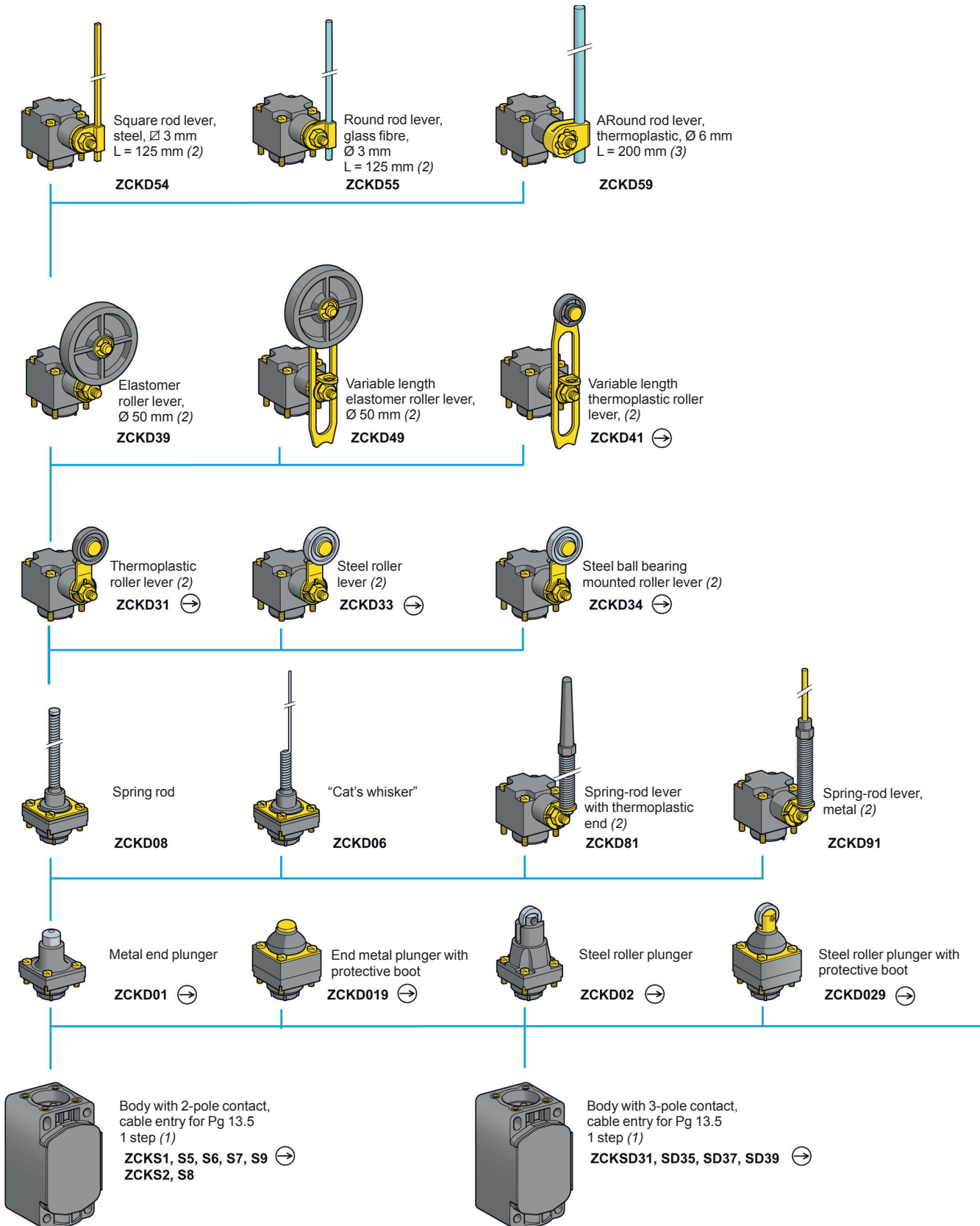

(1) For further details see page 1/98. For a cable entry tapped ISO M20 x 1.5, add **H29** to the reference.

Example: ZCKS1 becomes **ZCKS1H29**.

(2) Adjustable throughout 360° in 5° steps, or in 90° steps by reversing the notched washer.

(3) Adjustable throughout 360° in 5° steps, or in 45° steps by reversing the lever mounting.

Note: ZCKD heads can only be used with ZCKS bodies.

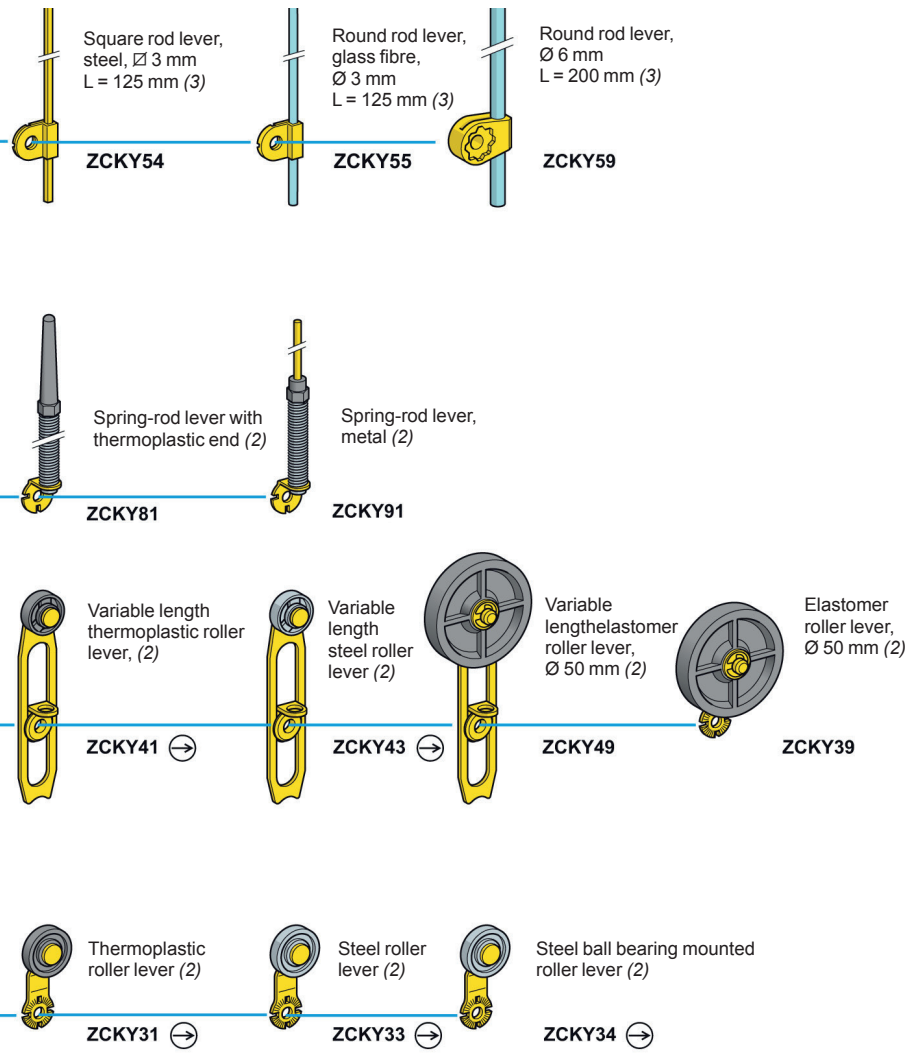

For actuation from left AND right or from left OR right

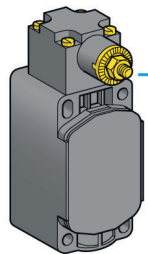
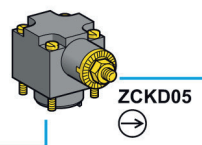

Body with double-pole 2 CO, staggered, snap action contact cable entry for Pg 13.5
2 step, 1 from left AND 1 from right (1)
ZCKS404

Limit switches

OsiSense XC Standard, format EN 50041

Plastic, double insulated, XCKS

Variable composition switches

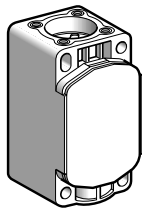

ZCKS●

Bodies with 2-pole contact

Type	With contact block	Scheme	Positive operation (1)	Cable entry	Reference	Weight kg
1 step	NC + NO snap action (XE2SP2151)		⊕	Pg 13.5	ZCKS1	0.080
				ISO M20 x 1.5	ZCKS1H29	0.080
	2 CO simultaneous, snap action (XESP3021)		-	Pg 13.5	ZCKS2	0.080
				ISO M20 x 1.5	ZCKS2H29	0.080
	NC + NO break before make, slow break (XE2NP2151)		⊕	Pg 13.5	ZCKS5	0.080
				ISO M20 x 1.5	ZCKS5H29	0.080
	NO + NC make before break, slow break (XE2NP2161)		⊕	Pg 13.5	ZCKS6	0.080
				ISO M20 x 1.5	ZCKS6H29	0.080
NC + NC simultaneous, slow break (XE2NP2141)		⊕	Pg 13.5	ZCKS7	0.080	
			ISO M20 x 1.5	ZCKS7H29	0.080	
NO + NO simultaneous, slow break (XE2NP2131)		-	Pg 13.5	ZCKS8	0.080	
			ISO M20 x 1.5	ZCKS8H29	0.080	
NC + NC snap action (XE2SP2141)		⊕	Pg 13.5	ZCKS9	0.080	
			ISO M20 x 1.5	ZCKS9H29	0.080	

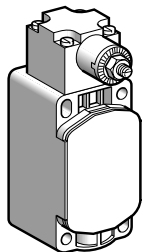

ZCKS404

Bodies with double-pole contact and spring return rotary head

Without operating lever

Type	With contact block	Scheme	Positive operation (1)	Cable entry	Reference	Weight kg
2 step 1 from left and 1 from right	2 CO staggered snap action		-	Pg 13.5	ZCKS404	0.150
				ISO M20 x 1.5	ZCKS404H29	0.150

Bodies with 3-pole contact and 1 cable entry

Type	With contact block	Scheme	Positive operation (1)	Cable entry	Reference	Weight kg
-	NC + NO + NO snap action (XE3SP2151)		⊕	Pg 13.5	ZCKSD31	0.080
				ISO M20 x 1.5	ZCKSD31H29	0.080
-	NC + NC + NO snap action (XE3SP2141)		⊕	Pg 13.5	ZCKSD39	0.080
				ISO M20 x 1.5	ZCKSD39H29	0.080
-	NC + NC + NO break before make, slow break (XE3NP2141)		⊕	Pg 13.5	ZCKSD37	0.080
				ISO M20 x 1.5	ZCKSD37H29	0.080
-	NC + NO + NO break before make, slow break (XE3NP2151)		⊕	Pg 13.5	ZCKSD35	0.080
				ISO M20 x 1.5	ZCKSD35H29	0.080

(1) ⊕: NC contact with positive opening operation or head assuring positive opening operation.

Limit switches

OsiSense XC Standard, format EN 50041

Plastic, double insulated, XCKS

Variable composition switches



XE2SP21●1

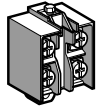

XE2NP21●1

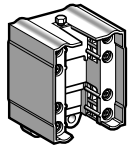

XESP3021

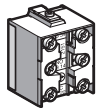

XE3●P21●●



DE9RA●●12

Contact blocks for ZCKS●● bodies

Type of contact	Scheme	For body	Positive operation (1)	Reference	Weight kg
2-pole contact					
NC + NO snap action		ZCKS1	⊙	XE2SP2151	0.020
NC + NO break before make, slow break		ZCKS5	⊙	XE2NP2151	0.020
2 CO simultaneous snap action		ZCKS2	-	XESP3021	0.045
NO + NC make before break, slow break		ZCKS6	⊙	XE2NP2161	0.020
NC + NC simultaneous, slow break		ZCKS7	⊙	XE2NP2141	0.020
NO + NO simultaneous, slow break		ZCKS8	-	XE2NP2131	0.020
NC + NC snap action		ZCKS9	⊙	XE2SP2141	0.020
3-pole contact					
NC + NO + NO snap action		ZCKSD31	⊙	XE3SP2151	0.035
NC + NC + NO snap action		ZCKSD39	⊙	XE3SP2141	0.035
NC + NC + NO break before make, slow break		ZCKSD37	⊙	XE3NP2141	0.035
NC + NO + NO break before make, slow break		ZCKSD35	⊙	XE3NP2151	0.035

Accessories for ZCKS●● and XCKS●●

Description	Minimum order quantity	Reference	Weight kg
Adaptator for 1/2" NPT conduit (male Pg 13.5 / female 1/2" NPT)	10	DE9RA1212	0.035
Adaptator for 1/2" NPT conduit (male M20 x 1.5 / female 1/2" NPT)	5	DE9RA2012	0.050

(1) ⊙ : NC contact with positive opening operation or sub-assembly assuring positive opening operation.

Other versions

Gold flashed contacts.

Please consult our Customer Care Centre.

Limit switches

OsiSense XC Standard, format EN 50041

Plastic, double insulated, XCKS

Variable composition switches

1

Heads ZCKD01, D109 with body

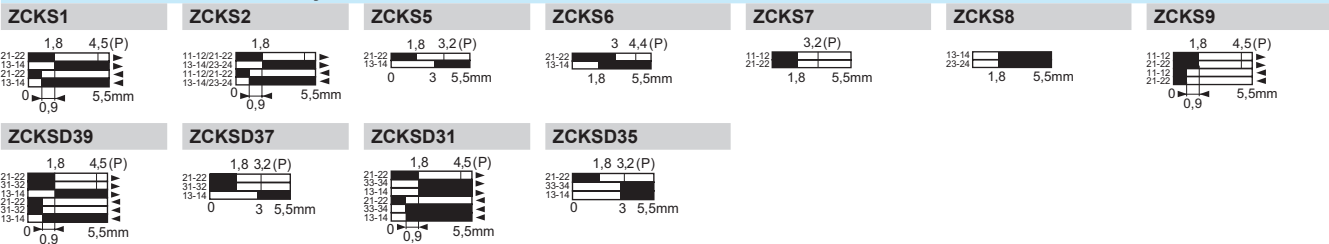

Heads ZCKD02, D029 with body

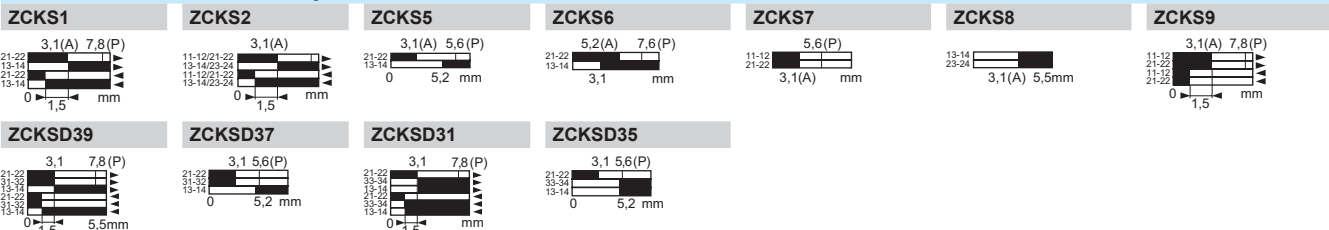

Heads ZCKD31, D33, D34 with body

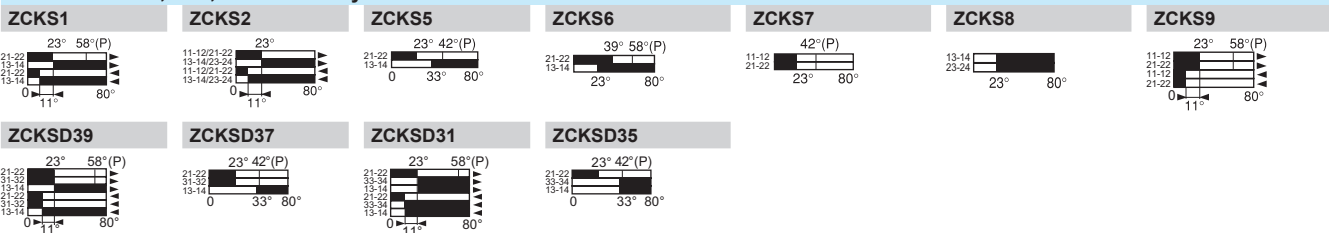

Heads ZCKD39, D41, D49, D54, D55, D59, D81, D91 with body

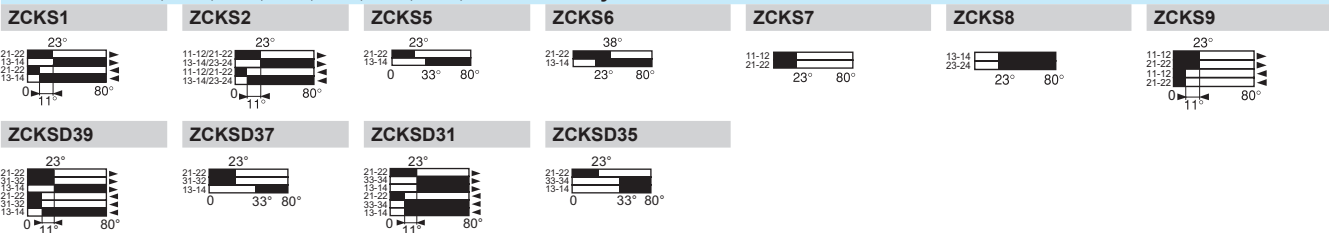

Heads ZCKD05 (positive operation only assured with a ↻ operating lever) with body

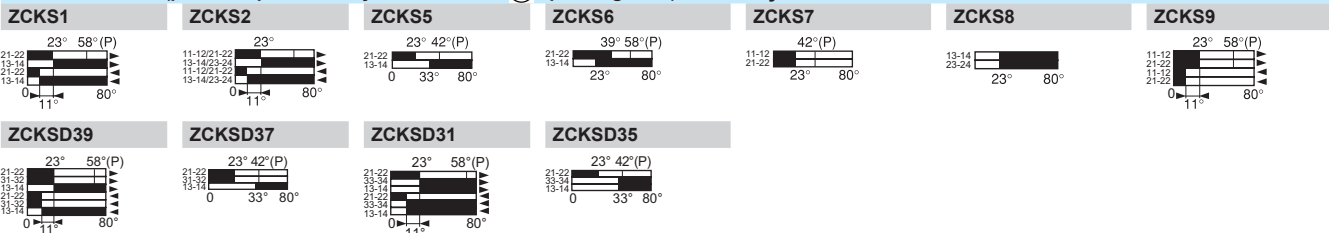

Heads ZCKD06, D08 with body

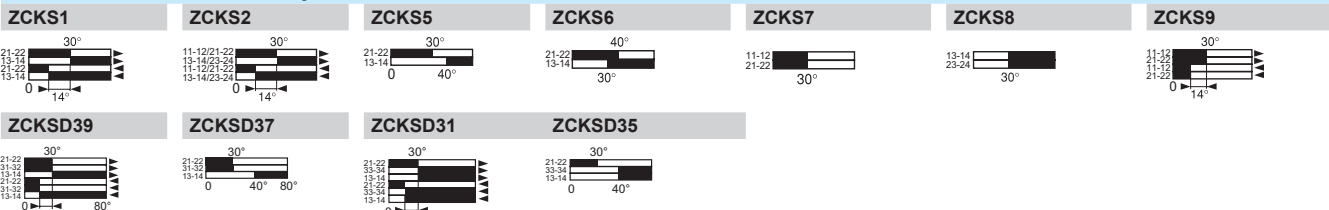

ZCKS404 (body with head)

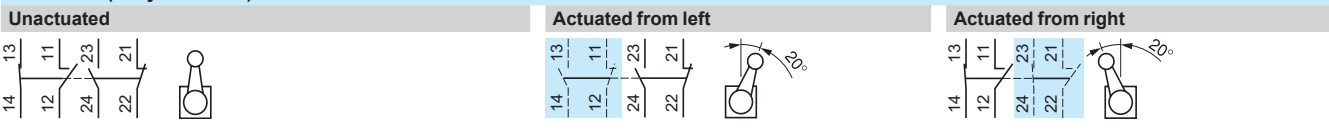

Contact operation

■ closed

□ open

(A) = cam displacement

(P) = positive opening point

Limit switches

OsiSense XC Standard, format EN 50041

Plastic, double insulated, XCKS

Variable composition switches

Plunger heads

ZCKD01

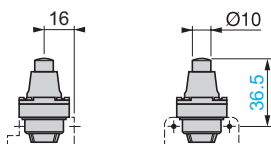

ZCKD019

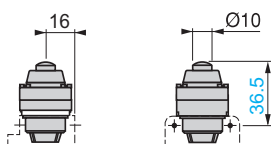

ZCKD02

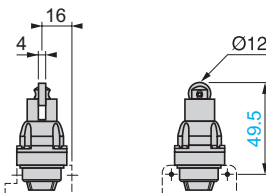

ZCKD029

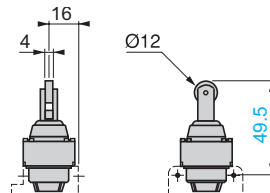

Rotary heads

ZCKD31, ZCKD33, ZCKD34

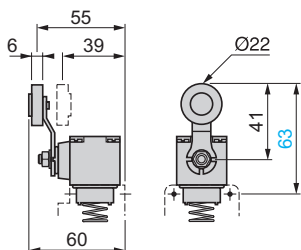

ZCKD39

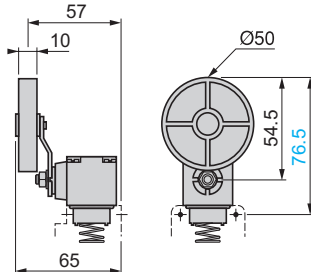

ZCKD41, ZCKD43

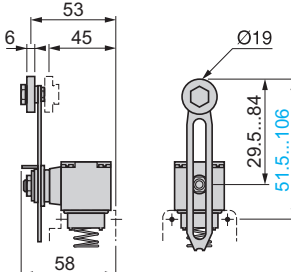

ZCKD49

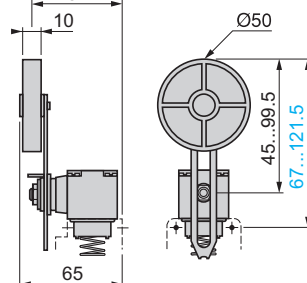

ZCKD54, ZCKD55, ZCKD59

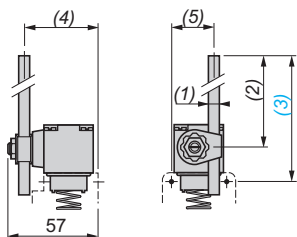

ZCK	(1) rod	(2)	(3)	(4)	(5)
D54	Ø 3, L = 125	115 max.	137 max.	49	24
D55	Ø 3, L = 125	115 max.	137 max.	49	24
D59	Ø 6, L = 200	190 max.	212 max.	46.5	26.2

ZCKD81

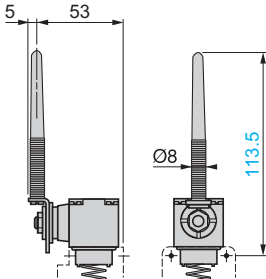

ZCKD91

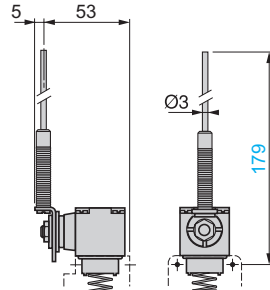

Note: operating lever spindle threaded M6.

Multi-directional heads

ZCKD06

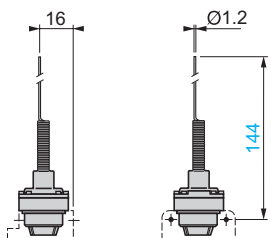

ZCKD08

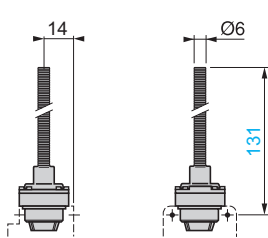

Bodies with contacts

ZCKS1, S2, S5, S6, S7, S8, S9
ZCKS1H29, S2H29, S5H29,
S6H29, S7H29, S8H29, S9H29
ZCKSD3, SD3H29

ZCKS404, S404H29

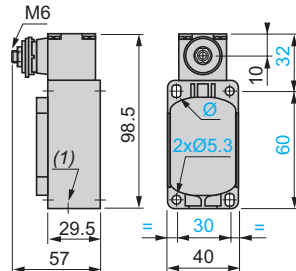
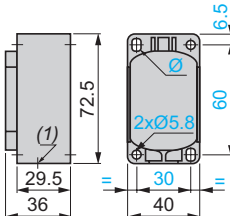

(1) 1 tapped entry for ISO M20 x 1.5 or Pg 13.5 cable gland.
Ø: 2 elongated holes 5.3 x 7.3.

Adaptators for 1/2" NPT conduit

DE9RA1212 (Pg 13.5)

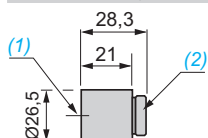

DE9RA2012 (M20)

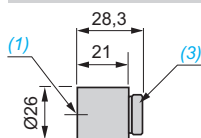

(1) Tapped entry for 1/2" NPT conduit.

(2) Pg 13.5 threaded sleeve.

(3) M20 x 1.5 threaded sleeve.